

# เครื่องซีลrink

## FL-5545TBH

High Speed Side Sealing and Shrinking Packagers



Model	FL-5545TBH
Machine dimension L X W X H (mm)	2040 x 1480 x 1300
Tunnel dimension L X W X H (mm)	/
Max packing size L (mm)	Unlimited
Max packing size W+H (mm)	≤ 400
Cross sealing L/H (mm)	450/150
Packing speed (pcs/min)	40-60
Conveyor speed (m/min)	40-60
Net weight (kg)	800
Power (kw)	3
Power supply	1PH110V / 220V 50/60Hz
Air pressure (kg/cm <sup>2</sup> )	6-8
Applicable film	POF

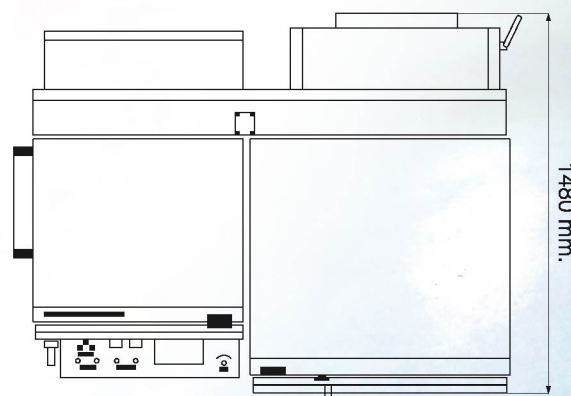
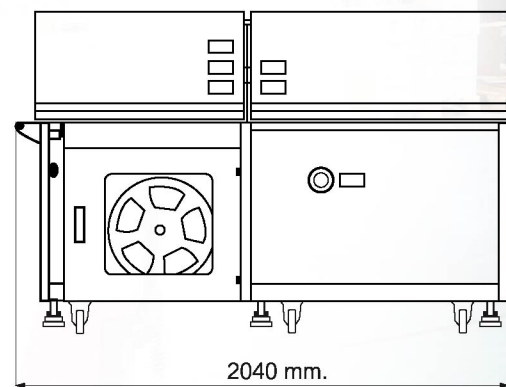

**MMP CORPORATION LTD.**  
บริษัท เอ็มเอ็มพี คอร์ปอเรชั่น จำกัด

3075/1-2 ถนนสุขุมวิท บางจาก พระโขนง กรุงเทพฯ 10260 โทร. 02-741-8444  
3075/1-2 SUKHUMVIT ROAD, BANGJAK, PRAKANONG, BANGKOK 10260 FAX : (662) 332-0514

[www.mmpcorp.co.th](http://www.mmpcorp.co.th)

# ตู้อบฟิล์มรีดร้อน

# SM-4525

## Shrink Tunnel

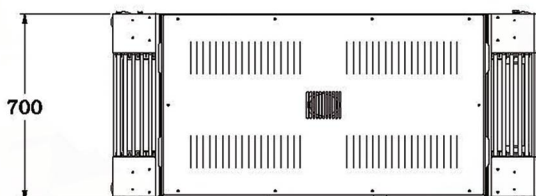
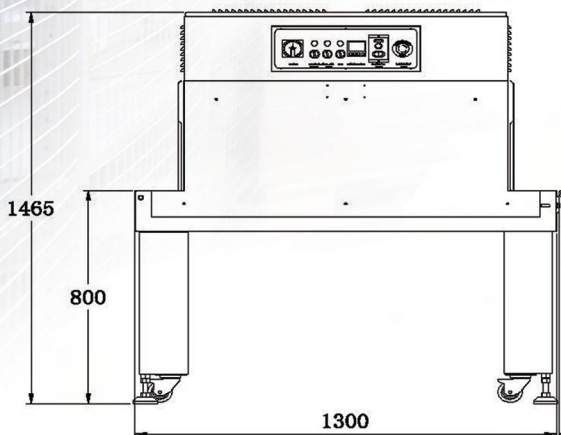

Model	SM-4525
Machine dimension L x W x H (mm)	1300 x 715 x 1455
Max packing size L x W x H (mm)	700 x 400 x 200
Size of Tunnel L x W x H (mm)	1000 x 450 x 250
Packing speed (pcs/h)	2000-3000
Net weight (kg)	260
Power (Kw)	8
Power supply	3 $\phi$ 220V / 380V / 50/60Hz